



# INFIELD THROWING DRILL 1

This drill is set up with the C at home, the 3B and 1B at their respective bases and the SS and 2B both close to second base to cover that base as appropriate. Each position is assigned a number as follows: C = 2, 1B = 3, 2B = 4, 3B = 5, SS = 6. The numbers will be used by the coach to tell the fielders where to throw. All throws will be in a pattern, starting and ending with the C. The coach will call the sequence of throws using the number as follows:

3 - 5 - 4. This sequence would be: C to 1B to 3B to 2B covering second base to C.

Other sequences would be:

6 - 5 - 3 C to SS covering 2B to 3B to 1B to C.

4 - 3 - 5 C to 2B covering second base to 1B to 3B to C.

5 - 3 - 6 C to 3B to 1B to SS covering second base to C.

After the above four sequences have been executed players rotate to the left, to the end of the line at the next position and the first player in the line moves in to handle the position. Continue the drill until every player has a turn at each position.

The fielders taking the throws can either tag the base as in a force out, or make a tag as if a runner was coming into the base. The drill can be competitive if the coach times each group on their four series of throws. The group with the lowest total time is the winner.

□ = BASE P = PLAYER

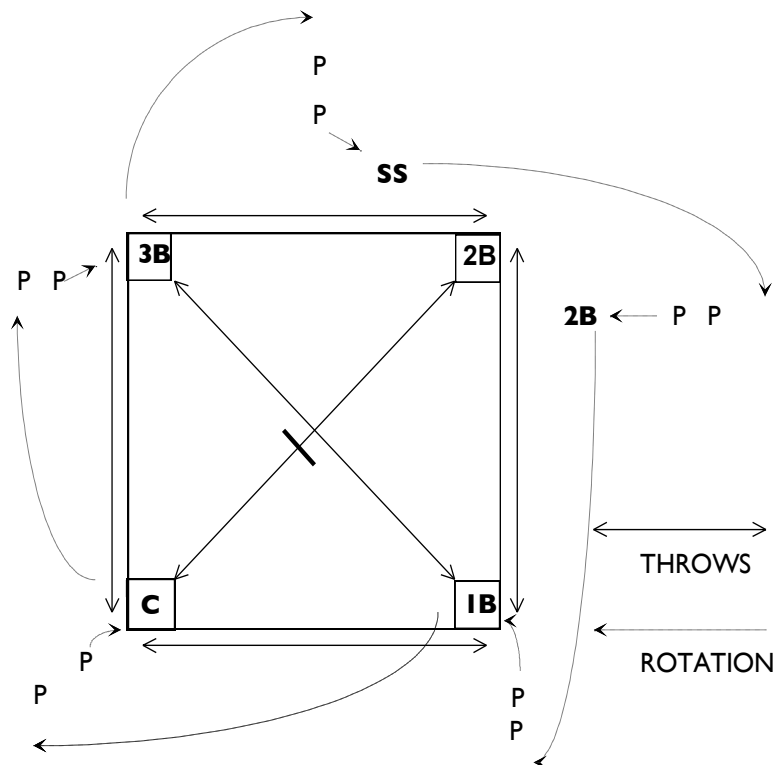

Reprinted with permission from **A Softball Coaches Tool Kit**